



# SELF-ADJUSTING SLEEVE™



Realization of Complete Automation

**Feature 1** Release from frequent line stops!

**Feature 2** Maintain optimal processing conditions!

## Outline dimensions

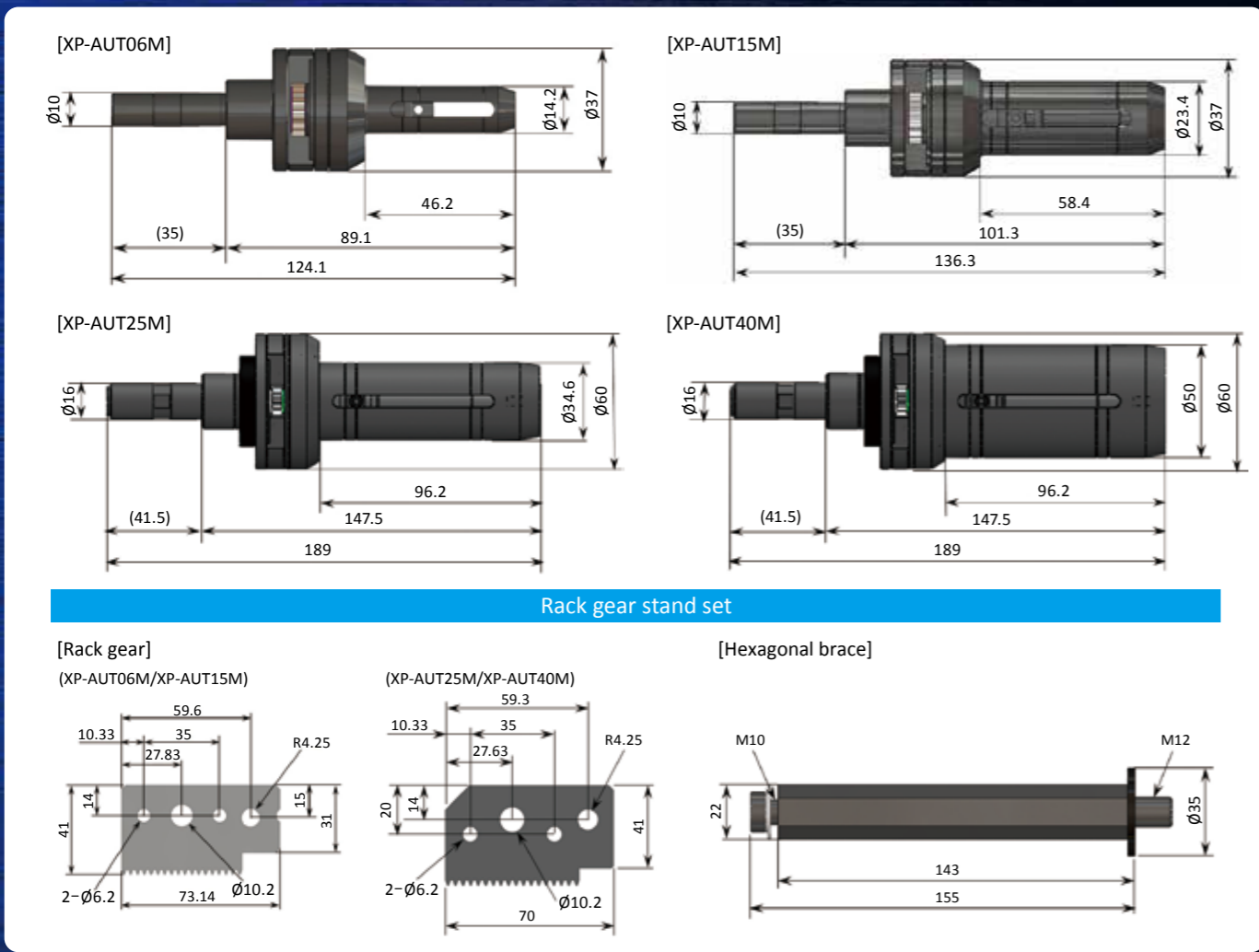

## Lineup

Product code	Overall length (mm)	Shank length (mm)	Outermost diameter (mm)	Shank diameter (mm)	Main body weight	Maximum rotation speed	Supporting brush
XP-AUT06M	124.1	35	φ37	φ10	220	10000	A13-CB06M, A11-CB06M, A21-CB06M, A31-CB06M
XP-AUT15M	136.3	35	φ37	φ10	270	6000	A13-CB15M, A11-CB15M, A21-CB15M, A31-CB15M
XP-AUT25M	189	41.5	φ60	φ16	795	5000	A11-CB25M, A21-CB25M, A31-CB25M
XP-AUT40M	189	41.5	φ60	φ16	910	3000	A11-CB40M, A21-CB40M, A31-CB40M

## Precautions for Use

Please make sure to read the user manual before use. In order to ensure safety, please observe the operator safety measures and operational precautions listed below. Please read XEBEC Brush™ Surface Instruction Manual for usage of XEBEC Brush™ Surface.

- [Operator safety measures]  
If these safety measures are neglected, there are following risks.
- If the tool fragments and/or chip powder gets into the eyes, there is the risk of losing eyesight in the worst case.
  - If the tool fragments and/or chip powder hit the skin, there is the risk of getting injured.
  - Dust generated by machining process may cause skin irritation or allergy.

- [Wear Protective Equipment]  
• Always wear safety glasses, protective gloves and masks when operating the tool. In addition, wear long sleeves and have the cuffs/bottom of the jacket properly closed to minimize skin exposure.

- [Beware of Grinding Powder]  
• Grinding powder and burrs may scatter within an area around the work as the brush revolves; therefore, please collect dust using a dust collector and stay clear of this area.

- [Caution to Your Surroundings]  
• Because it could be dangerous if tool fragments and/or chip powder scatter while working, enclose the potentially dangerous work area to prevent other people from entering, or have those around the work area wear protective equipment.

Please visit our homepage for details.

<http://www.xebec-tech.com>



XEBEC TECHNOLOGY CO.,LTD.  
ADD. 1-7-25, Koujimachi, Chiyoda-ku, Tokyo, 102-0083, Japan  
TEL. +81-(0)3-3239-3481 FAX. +81-(0)3-5211-8964  
URL <http://www.xebec-tech.com>  
E-mail [info@xebec-tech.com](mailto:info@xebec-tech.com)

Your Order

This product is an optional tool for XEBEC Brush™ Surface.

\*Use this product in place of XEBEC Sleeve™.

1. High grinding power
2. Consistent cutting quality
3. No deformation

By mounting XEBEC Self-Adjusting Sleeve™

4. Manual adjustment or projection is no longer necessary!
5. Maintain optimal conditions!

## Advantages of using the XEBEC Self-Adjusting Sleeve™

With XEBEC Self-Adjusting Sleeve™, manual projection adjustment is no longer necessary!

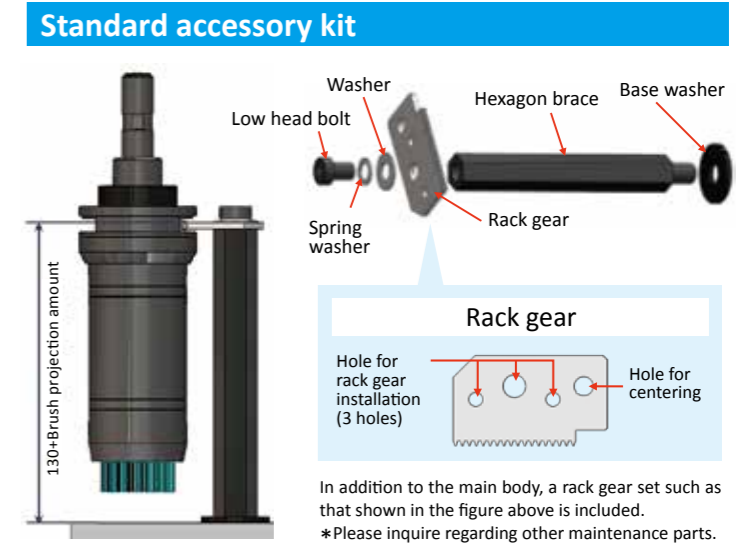
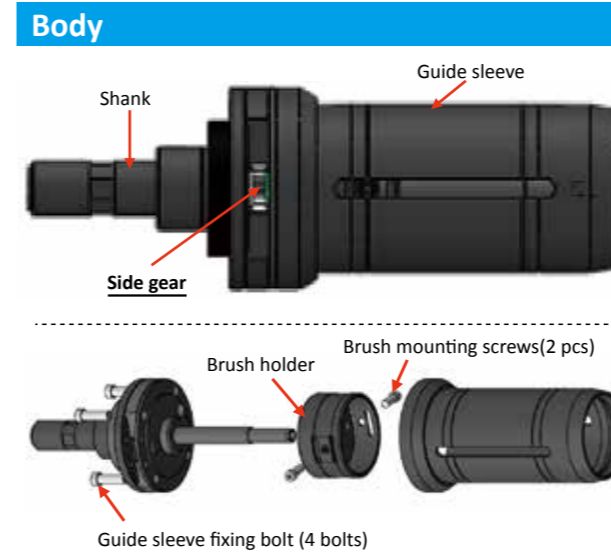
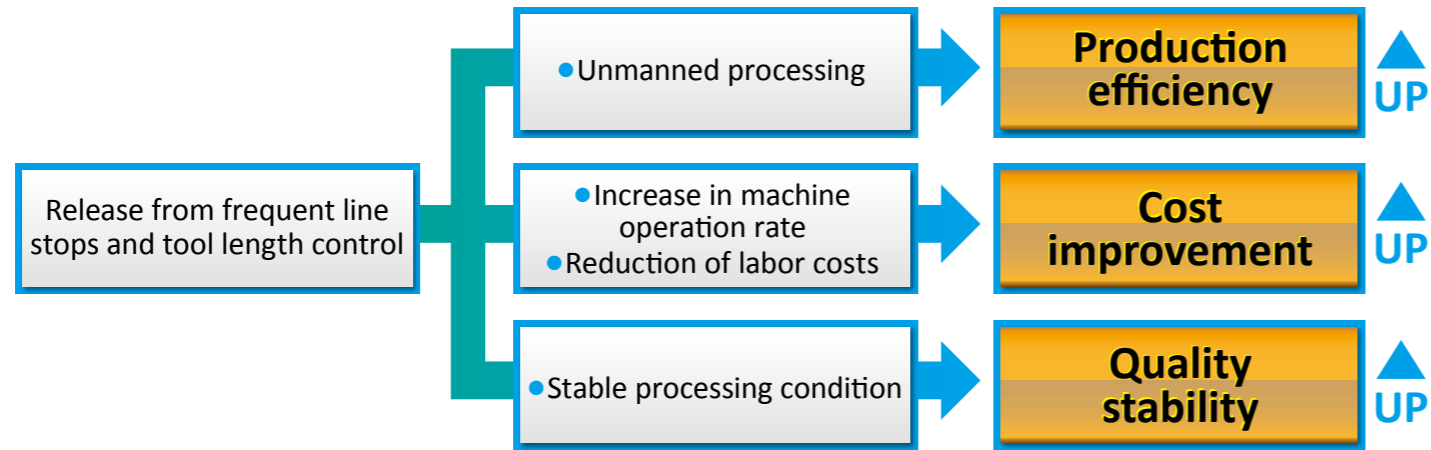

## How it works

- The side gear passing through the rack gear enables to adjust the arbitrary amount of projection.
- Projection can be set to your preferred length (0.05 to 1 mm).

### 1 Operation of the XEBEC Self-Adjusting Sleeve™

Passing through the rack gear, the side gear is rotated and the arbitrary amount of projection is adjusted.

#### Operation procedure

- Always check that mating gears are in the engaging direction.
- Adjust the positions and heights of the rack gear and side gear.

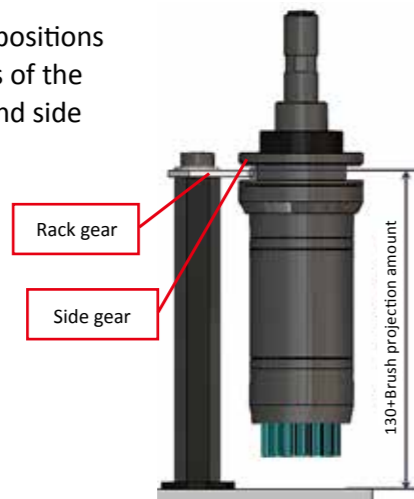
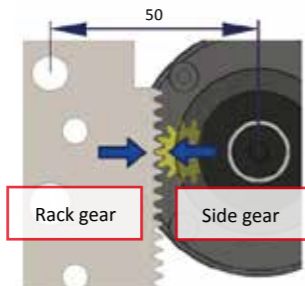

- As shown in the figure to the right, move the XEBEC Self-Adjusting Sleeve™ in the following order: A→B→C→D.
- By adjusting the passing through distance of B, the amount of projection can be arbitrarily set.

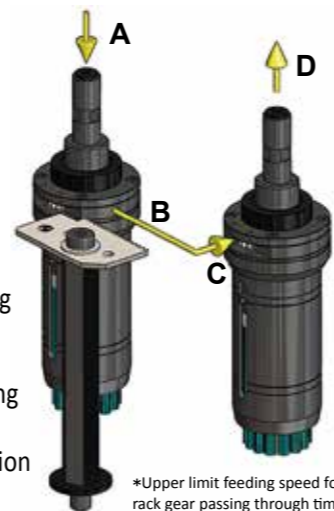

\*Upper limit feeding speed for rack gear passing through time : F=10000 mm/min

#### Amount of projection adjustment

An amount of projection of from 0.05 mm to 1 mm per operation can be set.

The amount of correction can be arbitrarily adjusted by increments of 50 μm.

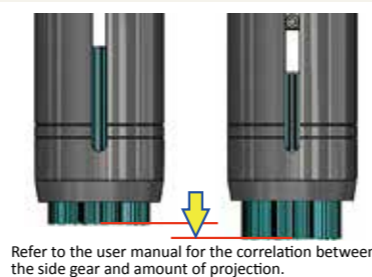

Refer to the user manual for the correlation between the side gear and amount of projection.

### 2 Check of the fixing of the XEBEC Self-Adjusting Sleeve™ and rack, and operation range

- Mount the rack gear to avoid interference (with fixtures etc) and in a position where the operation can be achieved (tool operation area) as shown in Fig. 2.
- Securely fix the rack gear. The inclination of the longitudinal direction of the rack gear to the slide axis has to be below 0.1mm.
- With the main spindle at its normal orientation angle, mount the tool assembly on the main spindle so that the side gear of the sleeve main body is directed towards the rack gear.

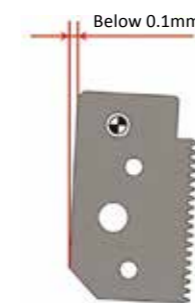

#### Operation range of XEBEC Self-Adjusting Sleeve™

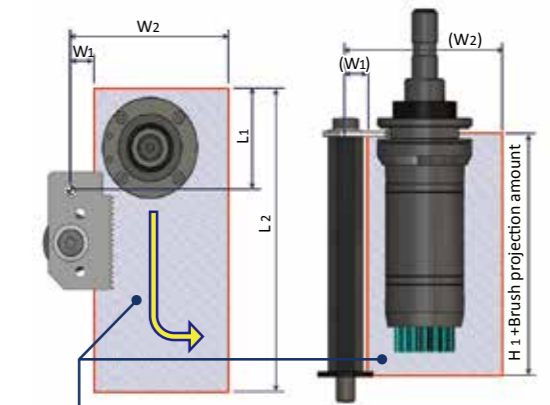

(Figure: Operation range when the XEBEC Self-Adjusting Sleeve™ passes through the rack gear)

Product code	W1(mm)	W2(mm)	L1(mm)	L2(mm)	H1(mm)
XP-AUT06M	10	75	50	155	85
XP-AUT15M	10	75	50	155	95
XP-AUT25M	15	100	60	180	130
XP-AUT40M	15	100	60	180	130

### 3 How to decide projection adjustment cycle

- Find the smallest depth of cut. Check the amount of brush wear by one process. Adjust the projection in arbitrary processes before deburring performance drops. (You do not have to adjust it by every process as long as burr can be removed.)

For example, when brush traveling distance is 2000mm and Brush wears 50μm, you adjust the projection every 10 process(0.5mm brush wear) or 40 process(2mm brush wear). It depends on your cycle time.